

Animal isolation device for experimental radiotherapy treatment

Isolation and immobilization system for test animals, preferably rats and mice, though also extensible to canids, porcids, primates, etc., that provides appropriate animal positioning during radiation, complying with the required hygiene and non-polluting conditions, because radiotherapy facilities are fundamentally for human use.

Description and essential characteristics

The device (1) is made up of two boxes or isolation chambers (10,20), arranged one inside the other. Each box is provided with its respective closure lid (the closure lids being not coincident with each other), holes (13,22) for the entrance of experimental treatment probes, ventilation ports (14,23), and in addition means of fixation (16) for air filters intended to be located on the ventilation ports. The holes and ventilation ports of the outer chamber are coincidental with the holes and ventilation ports of the inner box, respectively.

The system also consists of the following:

- Plugs to be inserted in the holes and ventilation ports, thereby achieving air tight hermetic sealing of the device.
- Immobilization means (15), which are permanently or temporarily joined, adhered or fixed to the internal surface of the inner box so as to achieve the optimal animal adherence, thus avoiding animal movements inside the box.

The design of the device guarantees the perfect isolation of the animal, which is located within the inner chamber.

The system also includes external pouches arranged in one of its sides that allow the introduction of the user's hands for handling the animal under hygiene and isolation conditions.

The device could be manufactured with materials isodense with water, ideal for absorbed radiation dose calculations.

Competitive advantages

The different advantages provided by the device—animal fixation, immobilization and isolation, as well as conditions of safety and hygiene—make it feasible to use with either of the two main modalities of radiotherapy (external and brachytherapy).

Additionally, the device can be adapted to different sizes of animals, as well as varying levels of radiotherapy accuracy, including the higher ones corresponding to stereotactic systems.

The device can also be used in (human) clinical facilities, as it complies with the required conditions of isolation, safety and hygiene, and is non-polluting.

Type of collaboration sought

Cooperation is sought with any Party interested in partnering, licensing or investing in the technology, whether it be an investor to fund the project, a partner interested in getting involved in any of the various phases until its placement on the market, a patent licensee, etc. Organisations potentially interested in this technology are those devoted to the manufacture, commercialisation and/or distribution of healthcare products, particularly medical devices; as well as universities, hospitals, research centres and all types of institutions engaged in radiotherapy and medical imaging experimental research.

Current stage of development

R&D Phase

Current state of intellectual property

Spanish patent P201031519, granted in April 2013.
 International patent application PCT/ES2011/070709.

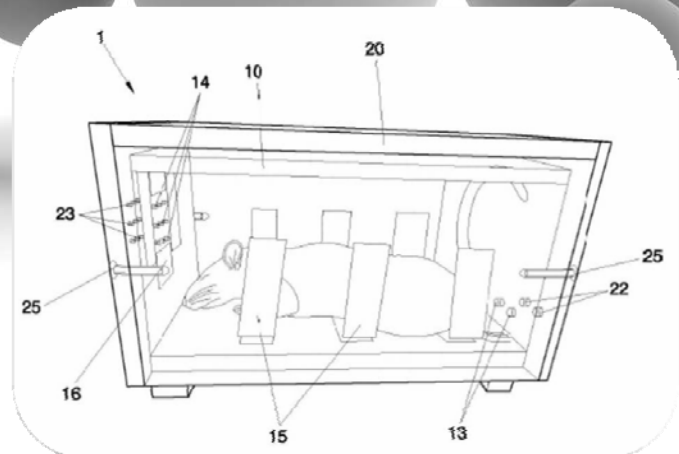

For further information, please contact

Innovation Unit
 Foundation for Biomedical Research of La Paz University
 Hospital (FIBHULP)-IdiPAZ
 Telephone number: +34 91 207 12 34
 e-mail: innovacion@idipaz.es
 Web: www.idipaz.es